

THIS DRAWING IS UNPUBLISHED.
 DIFFUSION RESTREINTE
 © COPYRIGHT 2011 by Tyco Electronics Corporation

RELEASED FOR PUBLICATION
 LIBRE A LA DIFFUSION
 ALL RIGHTS RESERVED.
 TOUTS DROITS RESERVES

2011

LOC	DIST
-	-

REVISIONS					
P	LTR REV	DESCRIPTION MODIFICATIONS	DATE	DWN DESS	APVD APPR
C		EQ00-0018-03	29-Jan-03	EN	-

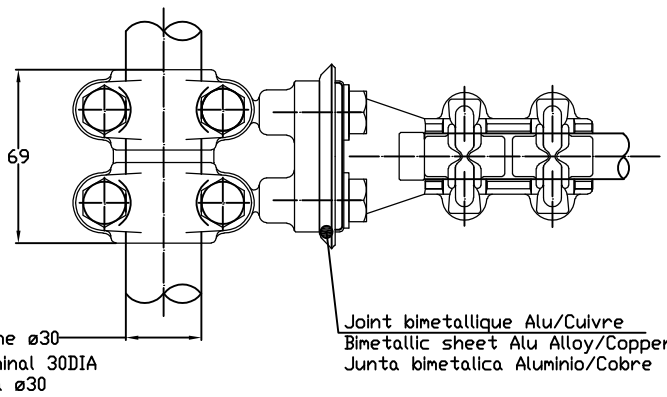
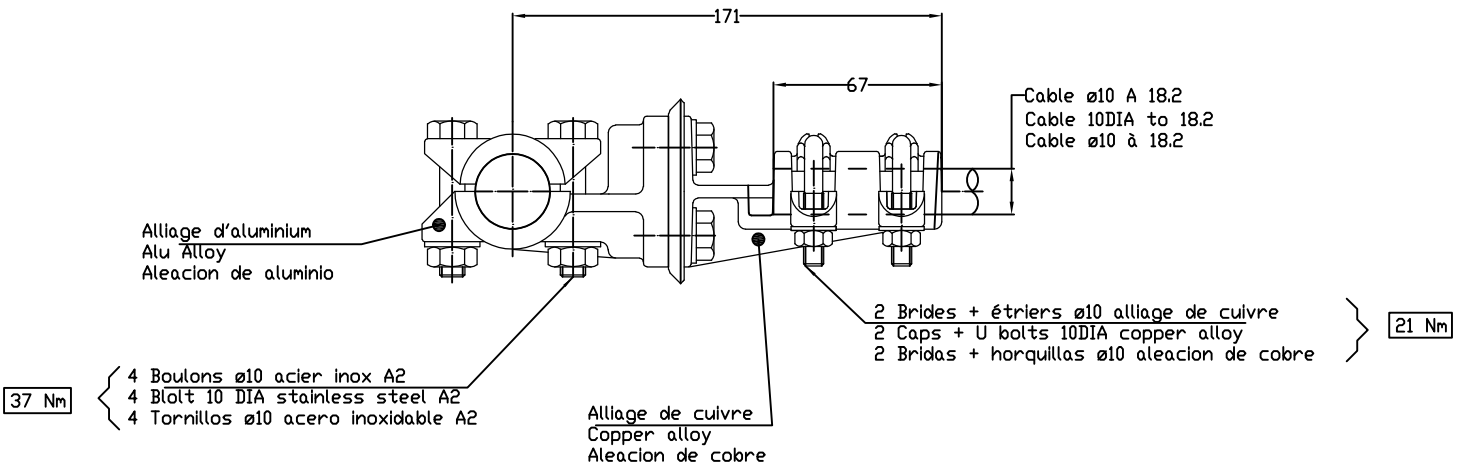

ITEM:

THIS DRAWING IS A CONTROLLED DOCUMENT. <small>CE D'AVANT EN AVANT CONSULTER LES RÈGLES GÉNÉRALES DE LA SOCIÉTÉ POUR DÉTERMINER LA NIVEAU DE CONTRÔLE CONCERNANT LE SERVICE TECHNIQUE DE TYCO ELECTRONICS S.A. 2011 0201-000001-00001-00001-00001-00001-00001</small>		DVN /DESSINE NIVVIS 29-Jan-03	STE <i>TE connectivity</i> <i>SIMEL PRODUCTS</i>	
DIMENSIONS: MM	TOLERANCES UNLESS OTHERWISE SPECIFIED PER TOLERANCES NON SPECIFIEES SELON : -	CHK/VERIFIE -	APVD/APPROUVE -	NAME TITRE S 966 30B 18
		PRODUCT SPEC SPEC. PRODUCT 02BFH0033	APPLICATION SPEC SPEC. APPLICATION -	SIZE FORMAT A3
MATERIAL MATIERE	FINISH FINITION	WEIGHT MASSE APPROX. 1.8 Kg	CAGE CODE 00779	DRAWING NO No PLAN C=719204
CUSTOMER DRAWING /PLAN CLIENT		UNIQUEMENT POUR REFERENCE	SCALE ECHELLE 1/2	SHEET FEUILLE 1 OF DE 1
				RESTRICTED TO RESERVE A -
				REV C